

701-904 SmartSeries Handset/Speaker Amplifier with Auxiliary Jack

General Information

This manual is provided as a simple installation guide for the 701-904 SmartSeries Handset/Speaker Amplifier with Auxiliary Jack. For the complete installation, operation and maintenance manual please visit <http://www.gai-tronics.com/manuals>.

Temperature range..... -22° F to +158° F (-30° C to +70° C), operating and storage

Dimensions..... 8.12 H x 8.12 W x 6.12 D inches (206 x 206 x 155 mm), overall

Shipping weight..... 7.1 lbs (3.2 kg)

Installation

CAUTION This equipment is suitable for use in Class I, Division 2, Groups A, B, C and D or non-hazardous locations only when used with listed GAI-Tronics 702 or 703 series 120 V ac enclosures or; Class I, Div. 2, Groups A, B, C, D; Class II, Div. 2, Groups F and G; Class III, Div. 2, when used with listed GAI-Tronics 732, 732S, 733 or 733S series 120 V ac enclosures. Combinations of equipment in your system are subject to investigation by the local Authority Having Jurisdiction at the time of installation. See full product manual for additional information at www.gai-tronics.com.

This handset/speaker amplifier mates directly with the 702, 703, 732 and 733 series amplifier enclosures and is suitable for indoor or outdoor use.

The 701-904 SmartSeries Handset/Speaker Amplifier with Auxiliary Jack plugs directly into the enclosure. Use extra care not to damage the protruding latch wings of connector J2 located on the bottom edge of the amplifier during installation.

It also plugs into standard SmartSeries enclosures such as a SmartSeries station RTU enclosure, an Emergency Party Line (EPL) enclosure, or an enclosure that houses a party line End-of-Line (EOL) module. When installing the assembly in one of these enclosures, you must also connect the 10-conductor keyed ribbon cable to J2 on the bottom of the Speaker Amp/Power Supply PCBA. Be sure that the red line on the edge of the cable lines up with J2-pin 1.

Ensure that the connectors mate securely and then tighten the four screws in the corners of the front panel. The following figure shows installation and adjustment details. Please refer to it when you are installing and adjusting the amplifier.

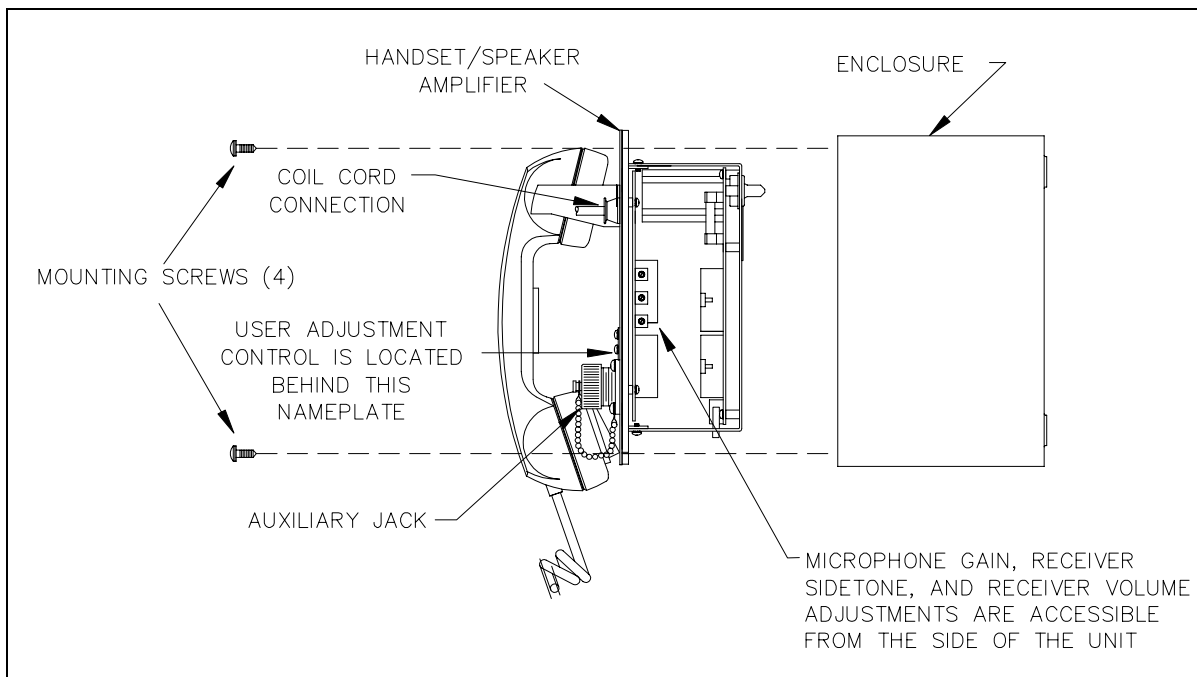

Figure 1.

Warranty

Equipment. GAI-Tronics warrants for a period of one (1) year from the date of shipment, that any GAI-Tronics equipment supplied hereunder shall be free of defects in material and workmanship, shall comply with the then-current product specifications and product literature, and if applicable, shall be fit for the purpose specified in the agreed-upon quotation or proposal document. If (a) Seller's goods prove to be defective in workmanship and/or material under normal and proper usage, or unfit for the purpose specified and agreed upon, and (b) Buyer's claim is made within the warranty period set forth above, Buyer may return such goods to GAI-Tronics' nearest depot repair facility, freight prepaid, at which time they will be repaired or replaced, at Seller's option, without charge to Buyer. Repair or replacement shall be Buyer's sole and exclusive remedy. The warranty period on any repaired or replacement equipment shall be the greater of the ninety (90) day repair warranty or one (1) year from the date the original equipment was shipped. In no event shall GAI-Tronics warranty obligations with respect to equipment exceed 100% of the total cost of the equipment supplied hereunder. Buyer may also be entitled to the manufacturer's warranty on any third-party goods supplied by GAI-Tronics hereunder. The applicability of any such third-party warranty will be determined by GAI-Tronics.

Services. Any services GAI-Tronics provides hereunder, whether directly or through subcontractors, shall be performed in accordance with the standard of care with which such services are normally provided in the industry. If the services fail to meet the applicable industry standard, GAI-Tronics will re-perform such services at no cost to buyer to correct said deficiency to Company's satisfaction provided any and all issues are identified prior to the demobilization of the Contractor's personnel from the work site. Re-performance of services shall be Buyer's sole and exclusive remedy, and in no event shall GAI-Tronics warranty obligations with respect to services exceed 100% of the total cost of the services provided hereunder.

Warranty Periods. Every claim by Buyer alleging a defect in the goods and/or services provided hereunder shall be deemed waived unless such claim is made in writing within the applicable warranty periods as set forth above. Provided, however, that if the defect complained of is latent and not discoverable within the above warranty periods, every claim arising on account of such latent defect shall be deemed waived unless it is made in writing within a reasonable time after such latent defect is or should have been discovered by Buyer.

Limitations / Exclusions. The warranties herein shall not apply to, and GAI-Tronics shall not be responsible for, any damage to the goods or failure of the services supplied hereunder, to the extent caused by Buyer's neglect, failure to follow operational and maintenance procedures provided with the equipment, or the use of technicians not specifically authorized by GAI-Tronics to maintain or service the equipment. **THE WARRANTIES AND REMEDIES CONTAINED HEREIN ARE IN LIEU OF AND EXCLUDE ALL OTHER WARRANTIES AND REMEDIES, WHETHER EXPRESS OR IMPLIED BY OPERATION OF LAW OR OTHERWISE, INCLUDING ANY WARRANTIES OF MERCHANTABILITY OR FITNESS FOR A PARTICULAR PURPOSE.**

Return Policy

If the equipment requires service, contact your Regional Service Center for a return authorization number (RA#). Equipment should be shipped prepaid to GAI-Tronics with a return authorization number and a purchase order number. If the equipment is under warranty, repairs or a replacement will be made in accordance with the warranty policy set forth above. Please include a written explanation of all defects to assist our technicians in their troubleshooting efforts.

Call 800-492-1212 (inside the USA) or 610-777-1374 (outside the USA) for help identifying the Regional Service Center closest to you.